

SPT 40

SPARTAN
Quality, Engineering, Value



In today's environment of high and unpredictable fuel costs, high worker's compensation insurance rates, and high labor costs, Spartan's SPT 40 pup trailer is an excellent way to double your hauling capacity at 1/3 the cost of another truck. Additionally, both the container on the truck and the container on the trailer can be loaded and unloaded without the necessity to unhitch the SPT 40 trailer. The unloading time for this combination is exceptionally efficient.

Spartan Truck Company has been a leader in the manufacturing of Roll-Off trucks and trailers for the past 30 years. We are known for our high quality components and extremely durable, low-maintenance roll-off systems and trailers.

Significant Features

- Controls located both on the trailer and in the truck
- High strength steel rail tubes and high strength steel alloy rollers
- Load and unload and dump without disconnecting the pup trailer

Options

- Automatic Tarp system
- Full polyurethane fenders
- Hydraulic landing gear



12266 Branford Street
Sun Valley, CA 91352
Phone (818) 899-1111
Fax (818) 897-4366
email sales@spartantruck.com
website www.spartantruck.com



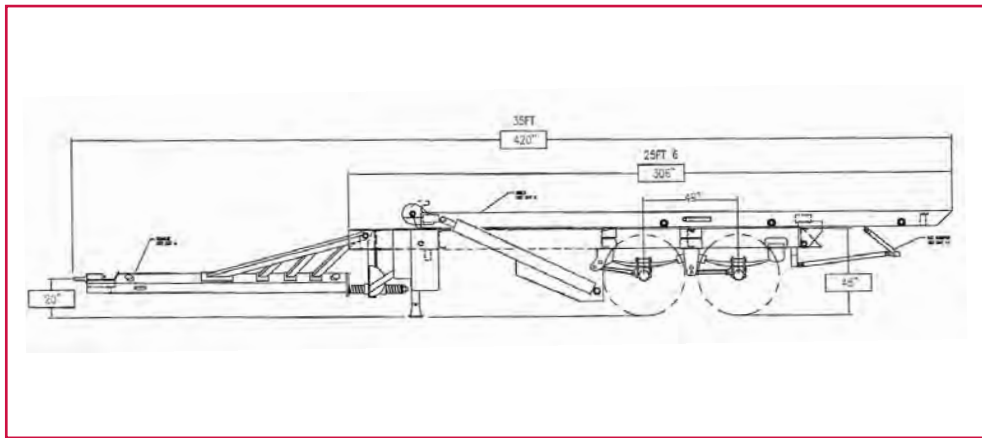

Features

Cable	3/4" x 77"
Cable Strength	66,800 lbs
Sheaves	10" Cast sheaves with 3" bronze inserts
Container Size	Up to 22'
Frame Rails	4" x 10" x 3/8" structural steel
Chassis Frame	Sub-frame 3/8 607 frame steel channel 10" x 34.5"
Rear Hinge	3/4" rear hinge plates welded to hoist sub frame, heat treated steel pins with zerks
Outside Frame	34.5" (optional 35.5)
Dump Angle	46 Degree
Weight	11,000 lbs
Payload	41,000 lbs maximum (based on truck axle assumptions: empty truck)
Outside Rollers	(6) 5" x 3.5" x 1.25" thru wall mount pins with zerks
Fenders	Quarter fenders
Lighting	LED Lights: 3-running lights, corner lights, brake and directional signal
Toolbox	Heavy duty toolbox with tarp basket
Adjustable Bin Stops	Moveable nose roller stops
Wear Strips	36" x 3" rail mounted wear strips
Lubrication	High quality zerk fittings – all wear points
Hoist Capacity	65,000 lbs
Hoist Cylinders	(2) 5.5" Bore x 2.5" Rod x 72" Stroke – Single Stage, Double acting
Reeving Cylinders	(2) 5.5" Bore x 2.5" Rod x 80" Stroke – Single Stage, Double acting
Tie Downs	Dual ratchet tie down with 4" straps
Safety Props	Quick release rail mounted props
Back up Alarm	Audible rear mounted alarm
Landing Gear	Manually cranked landing gear
Outside Controls	Dual lever hydraulically operated
Suspension	Transpro 3 leaf, 4 spring 45,000 lb
Axles	5" round beam axle, 25,000 lb minimum rating, 71.50 track, Spacing 49"
Paint	Gray primer base coating, gloss black enamel finish
Hub Wheels	Out board type 10 hole, 11 1/4 diameter bolt
Front Brakes	16.5" X 7" AIE, "S" cam with automatic slack adjuster
Rear Brakes	16.5" X 7" AIE "S" cam with automatic slack adjuster, and spring brakes
Wheels & Tires	11R / 22.5 on steel rims

Options

Tarping System, Inside Cab Controls, Aluminum Wheels, Hydraulic Landing Gear, Automatic Bin Locks, Full Fenders